

motostar TRAILERS

COMPETITION — ADVENTURE — HOLIDAY



*WARRIOR
SERIES*



500 Dowling Street, Wendouree Victoria 3355
P: 1800 677 344
sales@motostartrailers.com.au motostartrailers.com.au



If you want quality and resale value choose a Motostar Toy Hauler, you will not be disappointed!

OUR STORY:

Motostar Trailers have been operating for over 8 years. Every motorcycle enthusiast needs a sturdy, reliable and secure motorcycle trailer built to withstand the elements and specifically suit their individual needs. We have designed a range of trailers to fit your bikes perfectly and meet any further specifications you may have in mind. None of this hand-cut nonsense, we know machine cut trailers come up trumps so we exclusively use this method. Line cut steel & CNC routed components ensure our trailers are manufactured to the millimeter every time. Camping as well? No problem, we can build the trailer and camper into one. In the world of enclosed motorcycle trailers, there's not much we can't do.

FINANCE:

With our partner Blink Finance

Thinking about purchasing that Motostar Trailer you've always wanted? Our partner Blink Finance has Australia's leading Finance products to get you the cheapest trailer loan rates available. Whatever your situation may be, their comprehensive range of low interest finance options means you can find the ideal package that fits your budget and meets your needs.

Want to know more before you apply online? Simply call Blink Finance on 1300 827 848 and talk to one of their friendly finance specialists about any or concerns you might have.

FREIGHT:

With our partner Openica Logistics

We can arrange to freight your trailer Australia wide with the confidence your purchase will arrive with no damage. Openica logistics have depots in most states & provide a professional & reliable service. Alternatively we are happy for our customers to obtain their own freight company.

There are many online tender companies like Load shift or Freight Seek to obtain competitive quotes

WARRANTY:

Motostar Trailers are a registered trailer manufacturer. We build to the national code of practice and back our workmanship, materials & parts with a 12 month manufacturers warranty on our trailers

PAYMENT TERMS:

10% on order, 40% 6 weeks prior to start, 50% prior to pick up by electronic transfer

The advantages of choosing a Motostar Toy Hauler

The exterior:

Motostar have been using Ullrich Aluminium Composite Panel for the exterior and interior cladding for many years.

The product has proven to be both durable and strong. All components for the build are CNC routed for the fitting and assembly process of our toy haulers.



Motostar chassis & frame

Fully welded one piece chassis & sub frame for extra strength and longevity. Fabricated from Orrcon Duragal line cut steel for precision cutting every time. All welds are prepped, primed and coated in a galvanised spray.

Suspension & running gear:

Eye to eye shackle suspension for our single axle trailers & rocker roller suspension for the tandem trailers with overlay axles fitted as a standard option. Using the overlay axle allows the trailer to ride lower to the ground for ease of loading your bikes, especially road bikes.

The 4x4 option uses the same suspension systems with a straight beam axle or now with the option of Independent trailing arm suspension with individual stub axles for those who are looking to do a bit more off road work.

Single axle eye to eye shackle suspension

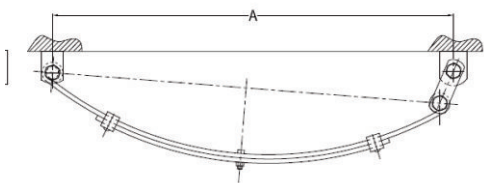

Tandem axle rocker roller suspension

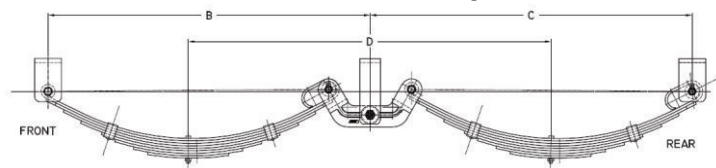

AL-KO independent trailing arm suspension

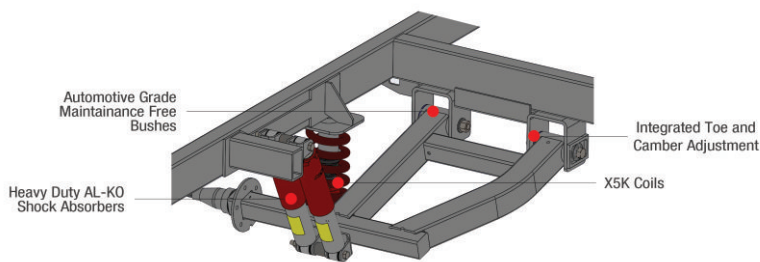

Positioned in front of PA door

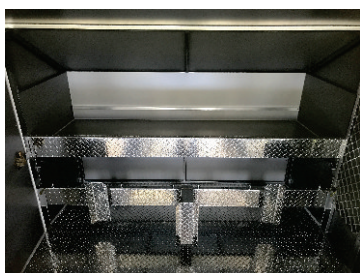

Positioned behind PA door with removable double in place

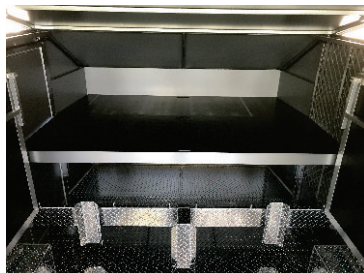

Positioned in front of PA door



Positioned in behind PA door



Securing your load:

Unique to Motostar our tie down system for your bikes is removable, adjustable and can be positioned either behind the PA door for easy access to your trailer or in front depending on how many bikes you are travelling with.

This system means no wheel wells or lashing rings to obstruct the floor space when moving around in the trailer & camping.

3 BIKE WARRIOR SERIES

OVERALL LENGTH 4800mm

WIDTH (exc, awning) 2200mm

INTERIOR LENGTH 3600mm

INTERIOR HEIGHT 1450mm - Pop Top 2000mm

OVERALL HEIGHT 2000mm - 4X4 2100mm

TILT PANEL ROOF

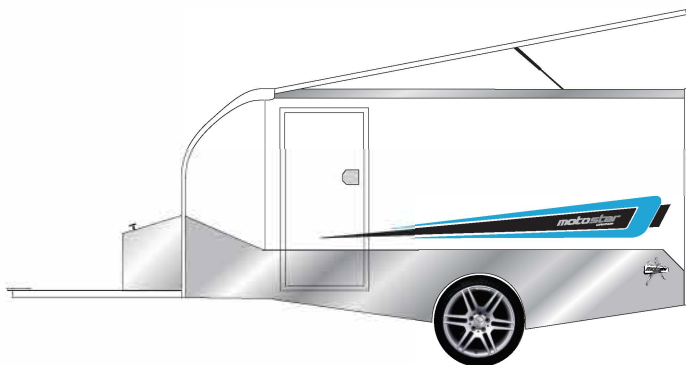

SPECIFICATIONS

TARE WEIGHT	800kg
ATM	1500kg
BALL WEIGHT	100kg
(Tare & ball weights will vary depending on accessories)	

RUNNING GEAR

SUSPENSION	1500kg EYE to EYE SHACKLE
AXLE	45mm OVERLAY AXLE
BRAKES	MECHANICAL DISK
HITCH	2000kg GAL OVERRIDE
WHEELS	14" ALLOYS
TYRES	195/R14 LIGHTTRUCK

BUILD MATERIALS

CHASSIS	100 X 50 X 3mm DURAGAL
SUB FRAME	25 X 25 - 50 X 25 X 2mm DURAGAL
FLOOR	3mm ALUMINIUM PROPELLER
CLADDING	3mm ALUMINIUM COMPOSITE
TRIM	ALUMINIUM

BASE PRICE INCLUSIONS:

Internal aluminium mesh lining
Removable wheel stop divider & lashing rings
Front shelf
PA door with water & dust proof seals
Ramp with water & dust proof seals
LED Lights, 4 Tail, 8 clearance, 1 number plate
7 Pin flat plug
Gas strut tilt panel roof
Enclosed draw bar
8" Swing away jockey wheel
Choice of graphic colours
6 months VIC registration

\$ 12,500+gst

4X4 TILT PANEL ROOF



SPECIFICATIONS

TARE WEIGHT	800kg
ATM	1500kg
BALL WEIGHT	100kg
(Tare & ball weights will vary depending on accessories)	

RUNNING GEAR

SUSPENSION	1500kg EYE to EYE SHACKLE (AL-KO Independent Suspension Optional Upgrade)
AXLE	45mm STRAIGHT BEAM
BRAKES	MECHANICAL DISK
HITCH	AL-KO OFF ROAD
WHEELS	15" ALLOYS
TYRES	235/75 R15 ALL TERRAIN

BUILD MATERIALS

CHASSIS	100 X 50 X 3mm DURAGAL
SUB FRAME	25 X 25 - 50 X 25 X 2mm DURAGAL
FLOOR	3mm ALUMINIUM PROPELLER
CLADDING	3mm ALUMINIUM COMPOSITE
TRIM	ALUMINIUM

BASE PRICE INCLUSIONS:

Internal aluminium mesh lining
Removable wheel stop divider & lashing rings
Front shelf
PA door with water & dust proof seals
Ramp with water & dust proof seals
LED Lights, 4 Tail, 8 clearance, 1 number plate
7 Pin flat plug
Gas strut tilt panel roof
Enclosed draw bar
8" Swing away jockey wheel
Choice of graphic colours
6 months VIC registration

\$ 13,700+gst

POP TOP

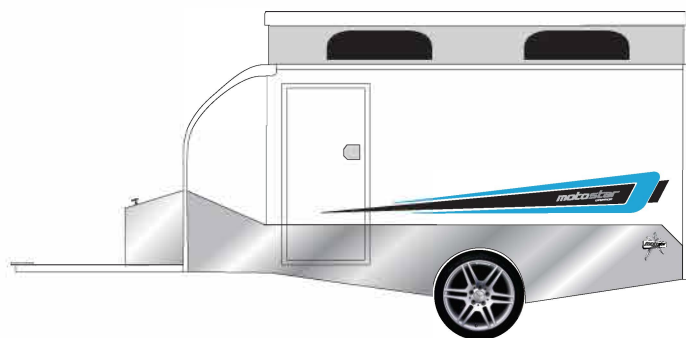

SPECIFICATIONS

TARE WEIGHT	850kg
ATM	1500kg
BALL WEIGHT	100kg
(Tare & ball weights will vary depending on accessories)	

RUNNING GEAR

SUSPENSION	1500kg EYE to EYE SHACKLE
AXLE	45mm OVERLAY AXLE
BRAKES	MECHANICAL DISK
HITCH	2000kg GAL OVERRIDE
WHEELS	14" ALLOYS
TYRES	195/R14 LIGHTTRUCK

BUILD MATERIALS

CHASSIS	100 X 50 X 3mm DURAGAL
SUB FRAME	25 X 25 - 50 X 25 X 2mm DURAGAL
FLOOR	3mm ALUMINIUM PROPELLER
CLADDING	3mm ALUMINIUM COMPOSITE
TRIM	ALUMINIUM

BASE PRICE INCLUSIONS:

Internal aluminium mesh lining
Removable wheel stop divider & lashing rings
Front shelf
PA door with water & dust proof seals
Ramp with water & dust proof seals
LED Lights, 4 Tail, 8 clearance, 1 number plate
7 Pin flat plug
Pop top gas strut roof & vinyl
Enclosed draw bar
8" Swing away jockey wheel
Choice of graphic colours
6 months VIC registration

\$ 17,500+gst

4X4 POP TOP

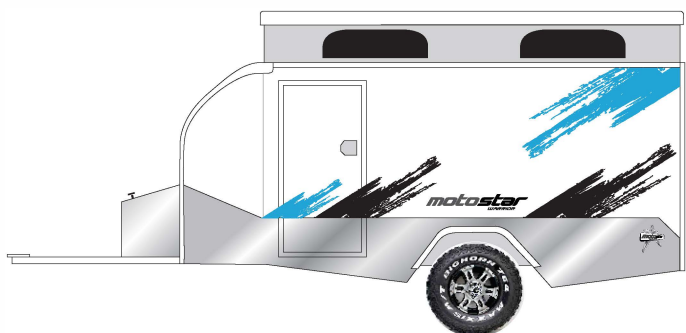

SPECIFICATIONS

TARE WEIGHT	850kg
ATM	1500kg
BALL WEIGHT	100kg
(Tare & ball weights will vary depending on accessories)	

RUNNING GEAR

SUSPENSION	1500kg EYE to EYE SHACKLE (AL-KO Independent Suspension Optional Upgrade)
AXLE	45mm STRAIGHT BEAM
BRAKES	MECHANICAL DISK
HITCH	AL-KO OFF ROAD
WHEELS	15" ALLOYS
TYRES	235/75 R15 ALL TERRAIN

BUILD MATERIALS

CHASSIS	100 X 50 X 3mm DURAGAL
SUB FRAME	25 X 25 - 50 X 25 X 2mm DURAGAL
FLOOR	3mm ALUMINIUM PROPELLER
CLADDING	3mm ALUMINIUM COMPOSITE
TRIM	ALUMINIUM

BASE PRICE INCLUSIONS:

Internal aluminium mesh lining
Removable wheel stop divider & lashing rings
Front shelf
PA door with water & dust proof seals
Ramp with water & dust proof seals
LED Lights, 4 Tail, 8 clearance, 1 number plate
7 Pin flat plug
Pop top gas strut roof & vinyl
Enclosed draw bar
8" Swing away jockey wheel
Choice of graphic colours
6 months VIC registration

\$ 18,150+gst

Build your dream Toy Hauler to your budget and needs by adding the available options.

3 BIKE WARRIOR SERIES FLOOR PLAN

OVERALL LENGTH 4800mm

WIDTH (exc, awning) 2200mm

INTERIOR LENGTH 3600mm

INTERIOR HEIGHT 1450mm - Pop Top 2000mm

OVERALL HEIGHT 2000mm - 4X4 2200mm

BASE PRICE LAYOUT

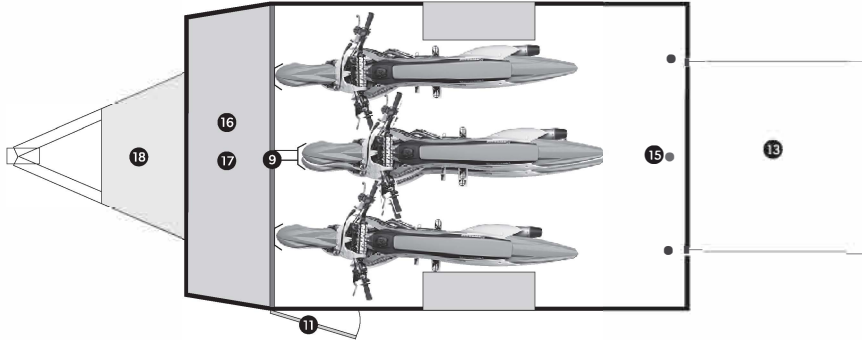

BIKE POSTION LAYOUT

PICTURED WITH SET BACK DIVIDER IN REAR POSITION WHEN TRAVELING ALLOWING DIRECT ACCESS INTO THE TRAILER

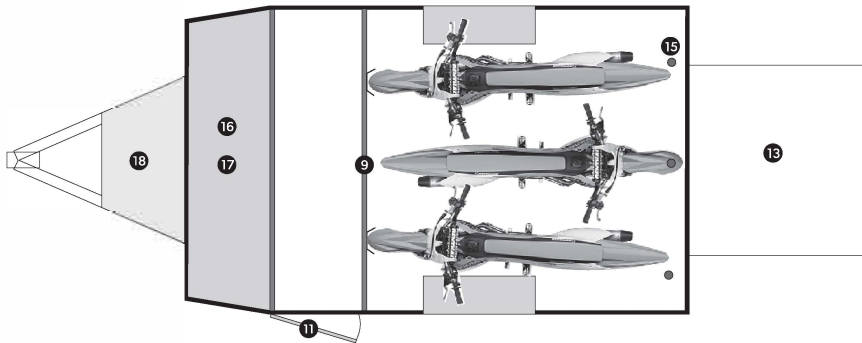

OPTIONS LAYOUT

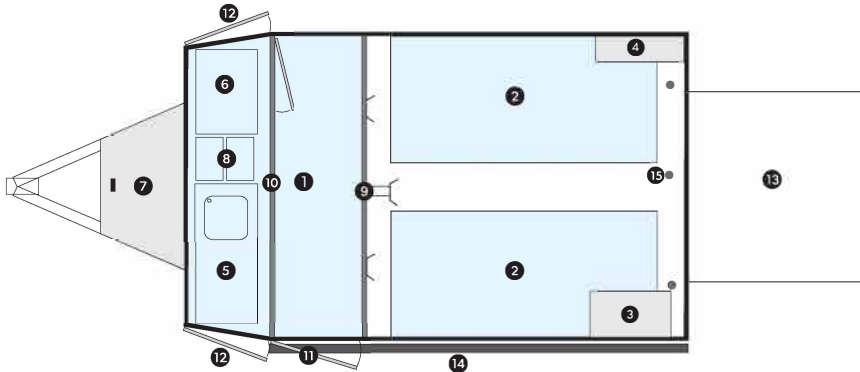

KEY:

- 1 1320 X 2200mm REMOVABLE DOUBLE BED
- 2 910 X 1880 FOLD UP SINGLE BEDS
- 3 TOOL BOX CABINET (cannot be fitted with beds)
- 4 INTERNAL SHELVING UNIT (cannot be fitted with beds)
- 5 S/S CAMP KITCHEN (single draw with sink & hand pump)
- 6 FRIDGE OR GENERATOR
- 7 DRAW BAR TOOL BOX
- 8 DUAL BATTERIES
- 9 REMOVABLE WHEEL STOP DIVIDER
- 10 STORAGE DIVIDER WITH ACCESS DOOR
- 11 ENTRY DOOR
- 12 STORAGE ACCESS DOORS
- 13 FOLD DOWN RAMP
- 14 3m FIAMMA AWNING
- 15 REAR LASHING RINGS
- 16 UNDER SHELF STORAGE SPACE
- 17 SHELF
- 18 ENCLOSED DRAW BAR

OPTIONAL INCLUSIONS:

Internal aluminium composite wall lining & insulation

Rear side door tool box cabinet

Rear side door 5 draw tool box to suite cabinet

Drivers side internal shelving unit

Draw bar tool box

Floor to top of front shelf divider with access door to storage.
(divides fridge, kitchen, luggage etc from bikes)

Front storage area duraslides for fridge, kitchen, Generator & luggage etc.

3m Fiamma F45s awning & custom fitting brackets

Fiamma Roof vents

S/steel camp kitchen, single draw with hand pump sink

Smev 2 burner gas cooker fitted to s/s kitchen (Plumbed to back of kitchen)

Removable front double bed

1320 x 2200mm x 100mm thick custom covered double bed foam mattress

2 fold down single beds (910 x 1880)

2 x 100mm thick single covered foam mattresses

125lt water tank, draw bar tap & 50 psi shurflo water pump.
(requires a battery system)

Marine carpet custom cut flooring

Alloy spare wheel & tyre to suit

17" alloys with 225/45R17 tyres

AL-KO Independent suspension

In house custom or company graphics

OPTIONAL ELECTRICAL INCLUSIONS

120amp Remco AGM batteries & battery box

100amp Remco AGM batteries & battery box

240v 15amp power inlet

Internal double power point & circuit breaker

Genuine Anderson plug & cables

8amp battery trickle charger

2 internal led ceiling strip lights

External led awning lights, 2 x side lights 600mm long

External led 2 x rear awning lights 250mm long

Dual acc/usb sockets on front shelf

Additional acc sockets

Sparrow air command 2.0kw reverse cycle roof top air conditioner
(requires the 240v power inlet & circuit breaker)

150w solar panel & 30amp solar charge regulator

12 pin trailer plug (trailer comes standard with 7 pin flat)

Redarc battery management system (BMS 1230s)

Engel & Weaco fridges (priced on preferred model)

12v digital tv, antenna & wall bracket

Fusion stereo & speakers

Electric Brakes

WHEEL OPTIONS

STARTING PRICE 14" x 6" WHEEL OPTIONS



DIGGA MACHINED BLACK ALLOY WITH 195/R14 LIGHT COMMERCIAL TYRES



KOYA 6 SPOKE ALLOY WITH 195/R14 LIGHT COMMERCIAL TYRES



DYNAMIC MACHINED BLACK ALLOY WITH 195/R14 LIGHT COMMERCIAL TYRES



DYNAMIC BLACK ALLOY WITH 195/R14 LIGHT COMMERCIAL TYRES

UPGRADE 17" x 7" WHEEL OPTIONS



PDW MANIC BLACK ALLOY WITH 225/45 R17 TYRES



PDW MANIC MACHINED BLACK ALLOY WITH 225/45 R17 TYRES



PDW POISON MACHINED BLACK ALLOY WITH 225/45 R17 TYRES

4X4 15" x 6.5" WHEEL OPTIONS



DYANIC MACHINED BLACK ALLOY WITH 235/75 R15 ALL TERRAIN TYRES



DYNAMIC BLACK ALLOY WITH 235/75 R15 ALL TERRAIN TYRES

GRAPHIC OPTIONS

CARBON

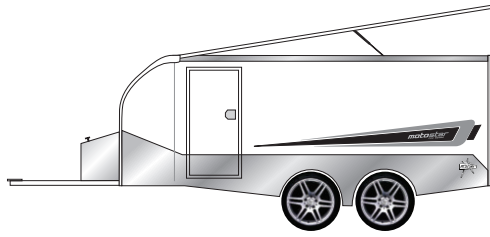

4X4 GRAPHIC

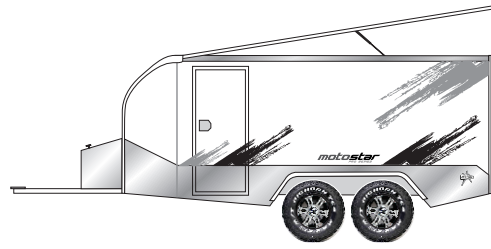

NEUTRAL GREY

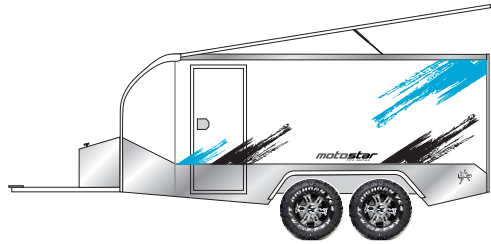
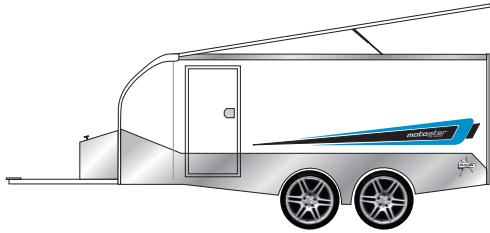

YAMAHA BLUE

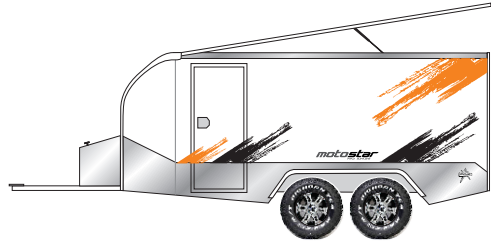
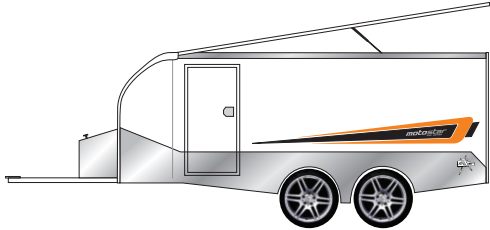

KTM ORANGE

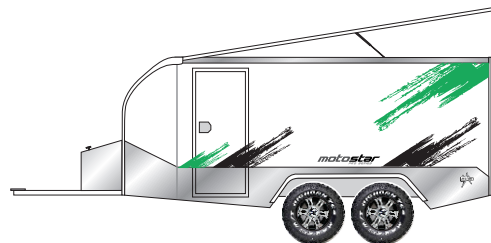
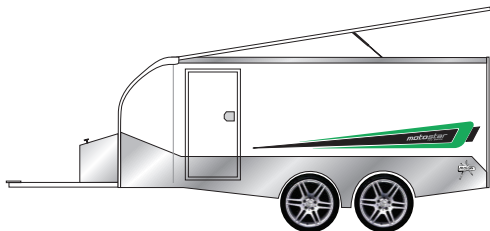

KAWASAKI GREEN

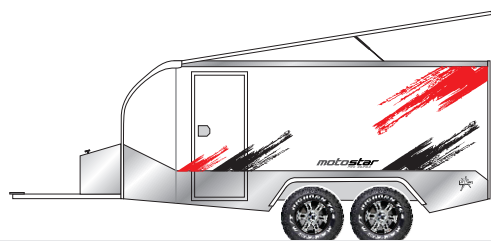
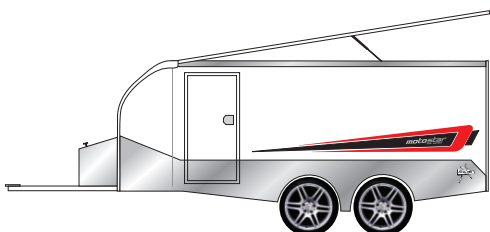

HONDA RED

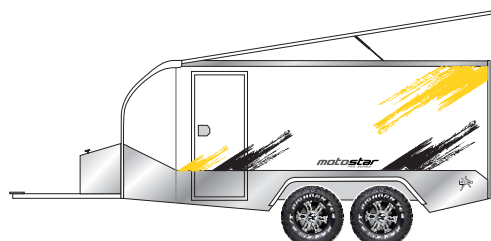
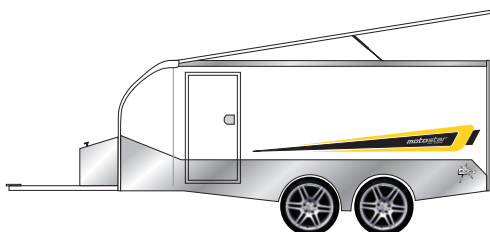

SUZUKI YELLOW

IN HOUSE CUSTOM OR COMPANY GRAPHICS AVAILABE

MODEL:		TICK THE REQUIRED MODEL & OPTION <input checked="" type="checkbox"/>
TILT PANEL ROOF	\$ 12,500+GST	<input type="checkbox"/>
4X4 TILT PANEL ROOF	\$ 13,700+GST	<input type="checkbox"/>
POP TOP	\$ 17,500+GST	<input type="checkbox"/>
4X4 POP TOP	\$18,150+GST	<input type="checkbox"/>

COLOURS:

EXTERIOR COLOUR: WHITE BLACK SILVER
TRIM COLOUR: WHITE BLACK

GRAPHICS: CARBON 4X4 GRAPHIC
GRAPHIC COLOUR: GREY BLUE ORANGE GREEN RED YELLOW

OPTIONAL INCLUSIONS: (Inc, GST & fitting)

INTERNAL ALUMINIUM COMPOSITE WALL LINING & INSULATION	\$ 1670.00	<input type="checkbox"/>
REAR SIDE DOOR TOOL BOX CABINET	\$ 1320.00	<input type="checkbox"/>
REAR SIDE DOOR 5 DRAW TOOL BOX TO SUITE CABINET	\$ 382.00	<input type="checkbox"/>
INTERNAL SHELVING UNIT	\$760.00	<input type="checkbox"/>
DRAW BAR TOOL BOX	\$ 880.00	<input type="checkbox"/>
FRONT NOSE CONE ACCESS DOORS	\$ 480.00 (each)	<input type="checkbox"/>
FLOOR TO TOP OF FRONT SHELF DIVIDER WITH ACCESS DOOR TO STORAGE.	\$ 605.00	<input type="checkbox"/>
FRONT STORAGE AREA DURASLIDES FOR FRIDGE, KITCHEN, GENERATOR & LUGGAGE ETC.	\$ 485.00 (each)	<input type="checkbox"/>
FIAMMA F45s AWNINGS & CUSTOM FITTING BRACKETS	\$ 1400.00 (3m Awning)	<input type="checkbox"/>
GRAY CANVAS CAMP PACK	\$ 1320.00	<input type="checkbox"/>
FIAMMA 28 HATCH STYLE ROOF VENTS	\$ 165.00 (Each)	<input type="checkbox"/>
S/STEEL CAMP KITCHEN, SINGLE DRAW WITH HAND PUMP SINK	\$ 1580.00 (Requires water tank & battery system)	<input type="checkbox"/>
SMEV 2 BURNER GAS COOKER FITTED TO S/S KITCHEN (Plumbed to back of kitchen only)	\$ 585.00	<input type="checkbox"/>
REMOVABLE FRONT DOUBLE BED	\$ 594.00	<input type="checkbox"/>
1320mm X 2200mm X 100mm THICK CUSTOM CUT & COVERED FOAM MATTRESS	\$ 550.00	<input type="checkbox"/>
2 FOLD DOWN SINGLE BEDS (910mm X 1880mm)	\$ 1200.00	<input type="checkbox"/>
2 X 100mm THICK SINGLE COVERED FOAM MATTRESSES	\$ 300.00	<input type="checkbox"/>
125lt WATER TANK, 50 PSI SHURFLO WATER PUMP & DRAW BAR TAP	\$ 920.00 (Requires battery system)	<input type="checkbox"/>
MARINE CARPET CUSTOM CUT FLOORING	\$ 360.00	<input type="checkbox"/>
SPARE ALLOY WHEEL & TYRE	\$ 275.00 14" / \$ 400.00 15" / \$ 400" 17"	<input type="checkbox"/>
17" X 7" ALLOY WHEEL & TYRE UPGRADE	\$400.00	<input type="checkbox"/>
AL-KO ENDURO 1.6t TRAILING ARM INDEPENDENT SUSPENSION, SINGLE SHOCK	\$ 3135.00	<input type="checkbox"/>
IN HOUSE CUSTOM OR COMPANY GRAPHICS	PRICED ON APPLICATION	<input type="checkbox"/>

OPTIONAL ELECTRICAL INCLUSIONS : (Inc, GST & Fitting)

120AMP REMCO AGM BATTERY & BATTERY BOX	\$ 420.00 (Dual Batteries) \$ 840.00	<input type="checkbox"/>
240V 15AMP POWER INLET	\$ 250.00	<input type="checkbox"/>
INTERNAL DOUBLE POWER POINT & CIRCUIT BREAKER	\$ 165.00	<input type="checkbox"/>
GENUINE ANDERSON PLUG & CABLES	\$220.00	<input type="checkbox"/>
8AMP BATTERY TRICKLE CHARGER	\$ 280.00	<input type="checkbox"/>
INTERNAL LED CEILING STRIP LIGHTS (ADDITIONAL LIGHTS \$ 99.00 Each)	\$ 275.00 (One over shelf, one centered of roof space)	<input type="checkbox"/>
EXTERNAL LED AWNING LIGHTS, 2 X SIDE LIGHTS 600mm LONG	\$ 315.00	<input type="checkbox"/>
EXTERNAL LED AWNING LIGHTS, 2 X REAR LIGHTS 250mm LONG	\$ 245.00	<input type="checkbox"/>
DUEL ACC/USB SOCKETS ON FRONT SHELF	\$ 180.00	<input type="checkbox"/>
ADDITIONAL ACC SOCKETS	\$ 120.00	<input type="checkbox"/>
SPARROW AIR COMMAND 2.0KW REVERSE CYCLE ROOF TOP AIR CONDITIONER	\$ 2399.00	<input type="checkbox"/>
150W ROOF TOP SOLAR PANEL WITH 30AMP SOLAR CHARGE REGULATOR	\$ 824.00	<input type="checkbox"/>
12 PIN TRAILER PLUG (TRAILERS COME STANDARD WITH A 7 PIN FLAT)	\$ 45.00	<input type="checkbox"/>
REDARC BATTERY MANAGEMENT SYSTEM (BMS 1230S)	\$ 1705.00	<input type="checkbox"/>
ENGEL & WEACO FRIDGES	PRICED ON APPLICATION	<input type="checkbox"/>
23.6" SPHERE ONYX 12V FHD LED TV, DVD COMBO ANTENNA & 2 ARM WALL BRACKET	\$ 1948.00	<input type="checkbox"/>
FUSION 50 SERIES STEREO, AM/FM WITH IPOD , 2 x 120W SPEAKERS & ARIAL	\$ 805.00	<input type="checkbox"/>
ELECTRIC BRAKES (One axle)	\$ 350.00	<input type="checkbox"/>

PAYMENT TERMS: 10% ON ORDER, 40% 6 WEEKS PRIOR TO START, 50% PRIOR TO PICK UP BY ELECTRONIC TRANSFER